

HORIZONTAL SAFETY PUMP SETS – GENERAL DESCRIPTION

Safety pump sets have been designed to centralise vacuum in all work environments such as hospitals, laboratories, etc. where vacuum must be guaranteed 24/7.

They are essentially composed of:

- A horizontal welded sheet steel tank with perfect vacuum seal.
- Two rotary vane vacuum pumps to be selected according to the required suction flow rate and level of vacuum.
- A vacuum gauge for a direct reading of the level of vacuum in the tank.
- Two manual valves for vacuum interception, located between the pumps and the tank and one installed on the tank, for the exclusion or connection of the pump set on a user system.
- A cock for condensation drainage.
- A switchgear enclosed in a special watertight metal casing with switches for automatic or manual pump operation, an alarm device with sound and light signal, alarm-test buttons and hour-counter for counting the hours of actual operation of every single pump.

These safety pump sets normally provide for the operation of one pump with subsequent automatic insertion of the second one for larger consumptions and when, for whatever reason, the plant level of vacuum goes under the preset value.

The automatic timed inverter, located on the switchboard, accurately alternates the pump start-up, so that they are both subject to the same mechanical wear.

The switchboard and remote alarm systems operate when the plant level of vacuum is below the set safety value.





HORIZONTAL SAFETY PUMP SETS DSO 300V ...

3D drawings are available on vuototecnica.net

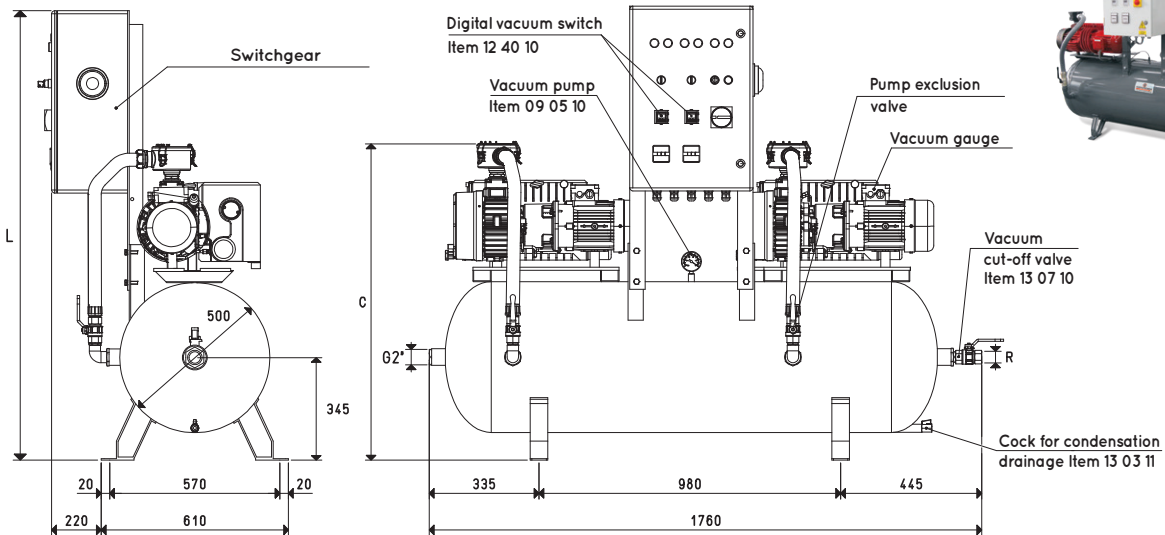

Item	Tank Litres	2 Pumps Mod.	Motor performance Volt	Switchgear item	C	L	R Ø	Weight Kg	Filter Accessories item
DSO 300V RVP 40	300	RVP 40	3 ~ 230/400-50Hz	DSO 300 97V	1005	1480	G1"1/2	204.8	FB 50 / FC 50
DSO 300V VTL 50/G1	300	VTL 50/G1	3 ~ 230/400-50Hz	DSO 300 97V	990	1480	G1"1/2	214.8	FB 50 / FC 50
DSO 300V RVP 60	300	RVP 60	3 ~ 230/400-50Hz	DSO 300 97V	1040	1480	G1"1/2	224.8	FB 50 / FC 50
DSO 300V VTL 75/G1	300	VTL 75/G1	3 ~ 230/400-50Hz	DSO 300 97V	1040	1480	G1"1/2	259.8	FB 50 / FC 50
DSO 300V RVP 100	300	RVP 100	3 ~ 230/400-50Hz	DSO 300 97V	1040	1480	G1"1/2	270.8	FB 50 / FC 50
DSO 300V VTL 105/G1	300	VTL 105/G1	3 ~ 230/400-50Hz	DSO 300 97V	1080	1480	G1"1/2	302.0	FB 50 / FC 50

Note: All RVP pumps ... are equipped as standard with an FC filter ... suitable for the size of their suction connection.

HORIZONTAL SAFETY PUMP SETS DSO 500V ...

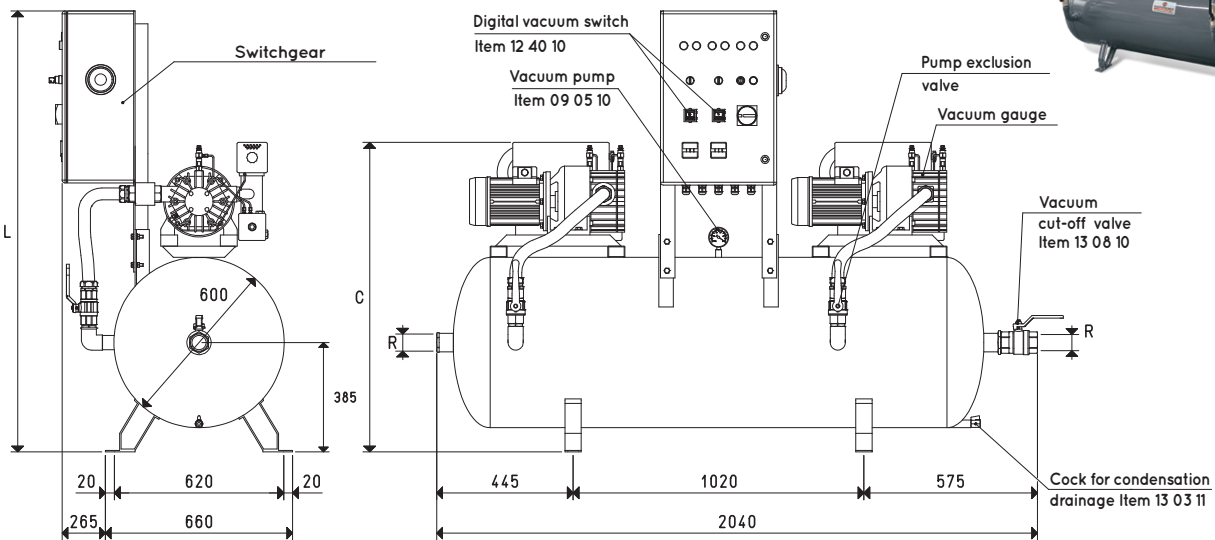

Item	Tank Litres	2 Pumps Mod.	Motor performance Volt	Switchgear item	C	L	R Ø	Weight Kg	Filter Accessories item
DSO 500V VTL 50/G1	500	VTL 50/G1	3 ~ 230/400-50Hz	DSO 300 97V	1090	1510	G2"	287.8	FB 60 / FC 60
DSO 500V RVP 60	500	RVP 60	3 ~ 230/400-50Hz	DSO 300 97V	1130	1510	G2"	297.0	FB 60 / FC 60
DSO 500V VTL 75/G1	500	VTL 75/G1	3 ~ 230/400-50Hz	DSO 300 97V	1140	1510	G2"	332.8	FB 60 / FC 60
DSO 500V RVP 100	500	RVP 100	3 ~ 230/400-50Hz	DSO 300 97V	1130	1510	G2"	343.3	FB 60 / FC 60
DSO 500V VTL 105/G1	500	VTL 105/G1	3 ~ 230/400-50Hz	DSO 300 97V	1180	1510	G2"	375.0	FB 60 / FC 60
DSO 500V RVP 160	500	RVP 160	3 ~ 230/400-50Hz	DSO 300 97V	1430	1510	G2"	475.0	FB 60 / FC 60
DSO 500V RVP 200	500	RVP 200	3 ~ 230/400-50Hz	DSO 300 97V	1430	1510	G2"	481.0	FB 60 / FC 60

Note: All RVP pumps ... are equipped as standard with an FC filter ... suitable for the size of their suction connection.

Transformation ratio: N (newton) = Kg x 9.81 (force of gravity)

$$\text{inch} = \frac{\text{mm}}{25.4}; \text{pounds} = \frac{\text{g}}{453.6} = \frac{\text{Kg}}{0.4536}$$

Adapters for GAS - NPT threading available on page 1.130

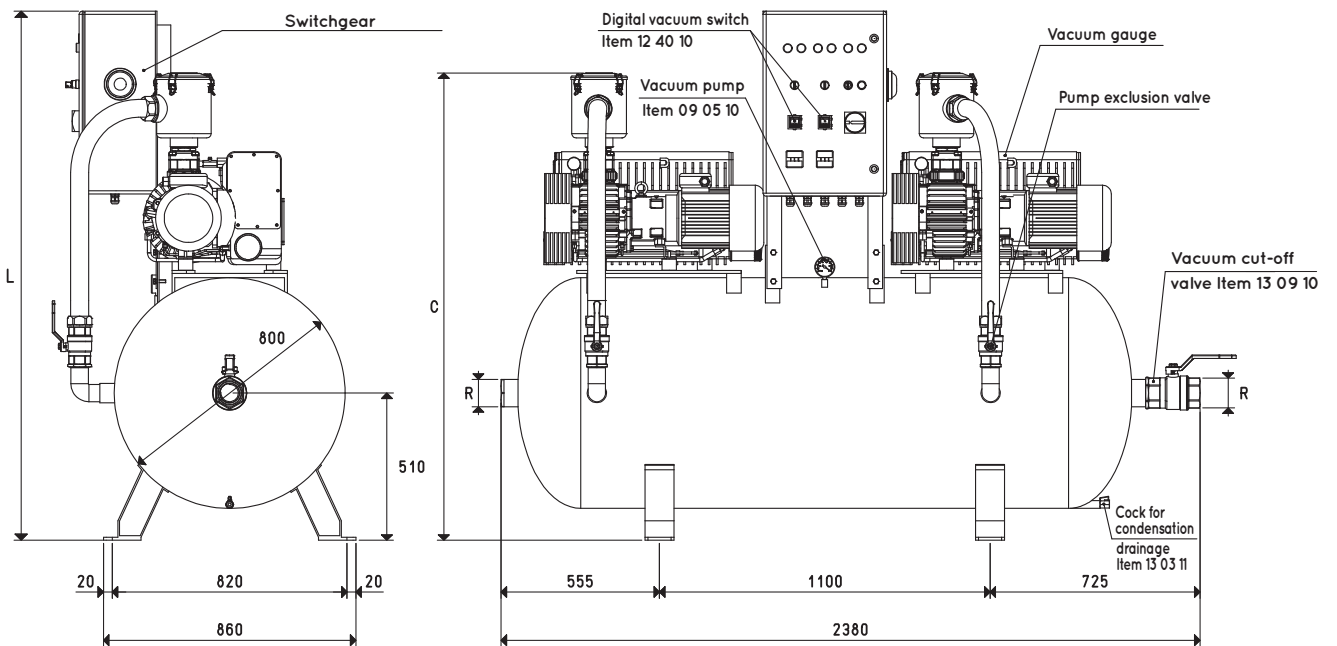

Item	Tank Litres	2 Pumps Mod.	Motor performance Volt	Switchgear item	C	L	R Ø	Weight Kg	Filter Accessories item
DSO 1000V RVP 60	1000	RVP 60	3 ~ 230/400-50Hz	DSO 300 97V	1318	1730	G3"	366.8	FC 80
DSO 1000V VTL 75/G1	1000	VTL 75/G1	3 ~ 230/400-50Hz	DSO 300 97V	1380	1730	G3"	389.8	FC 80
DSO 1000V RVP 100	1000	RVP 100	3 ~ 230/400-50Hz	DSO 300 97V	1298	1730	G3"	396.8	FC 80
DSO 1000V VTL 105/G1	1000	VTL 105/G1	3 ~ 230/400-50Hz	DSO 300 97V	1430	1730	G3"	432.0	FC 80
DSO 1000V RVP 160	1000	RVP 160	3 ~ 230/400-50Hz	DSO 300 97V	1678	1730	G3"	446.0	FC 80
DSO 1000V RVP 200	1000	RVP 200	3 ~ 230/400-50Hz	DSO 300 97V	1678	1730	G3"	452.0	FC 80
DSO 1000V RVP 250	1000	RVP 250	3 ~ 400/690-50Hz	DSO 300 97V	1639	1730	G3"	545.2	FC 80
DSO 1000V RVP 300	1000	RVP 300	3 ~ 400/690-50Hz	DSO 300 97V	1639	1730	G3"	573.2	FC 80

Note: All RVP pumps ... are equipped as standard with an FC filter ... suitable for the size of their suction connection.

Transformation ratio: N (newton) = Kg x 9.81 (force of gravity)

inch = $\frac{mm}{25.4}$; pounds = $\frac{g}{453.6} = \frac{Kg}{0.4536}$

Adapters for GAS - NPT threading available on page 1.130

VERTICAL SAFETY PUMP SETS - GENERAL DESCRIPTION

Safety pump sets have been designed to centralise vacuum in all work environments such as hospitals, laboratories, etc. where vacuum must be guaranteed 24/7.

They are essentially composed of:

- A vertical welded sheet steel tank with perfect vacuum seal.
- Two rotary vane vacuum pumps to be selected according to the required suction flow rate and level of vacuum.
- A vacuum gauge for a direct reading of the level of vacuum in the tank.
- Two manual valves for vacuum interception, located between the pumps and the tank and one installed on the tank, for the exclusion or connection of the pump set on a user system.
- A cock for condensation drainage.
- A switchgear enclosed in a special watertight metal casing with switches for automatic or manual pump operation, an alarm device with sound and light signal, alarm-test buttons and hour-counter for counting the hours of actual operation of every single pump.

These safety pump sets normally provide for the operation of one pump with subsequent automatic insertion of the second one for larger consumptions and when, for whatever reason, the plant level of vacuum goes under the preset value.

The automatic timed inverter, located on the switchboard, accurately alternates the pump start-up, so that they are both subject to the same mechanical wear.

The switchboard and remote alarm systems operate when the plant level of vacuum is below the set safety value.





VERTICAL SAFETY PUMP SETS DSV 150V ..

3D drawings are available on vuotecnica.net

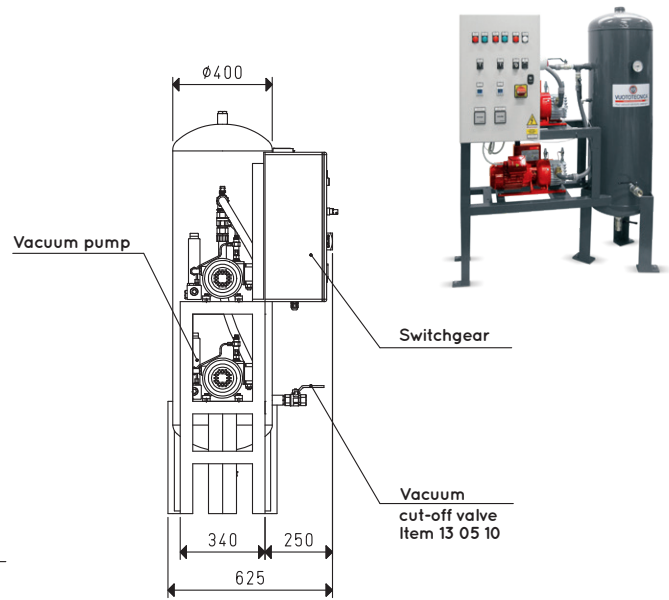
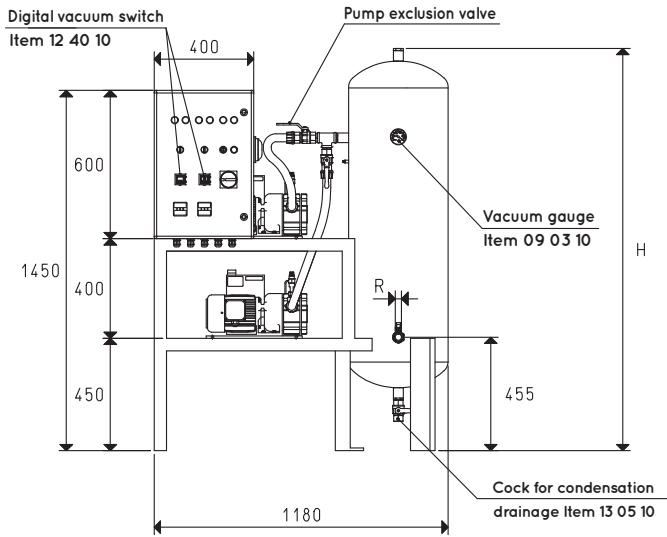

Item	Tank Litres	2 Pumps Mod.	Motor performance Volt	Switchgear item	H	R Ø	Weight Kg	Filter Accessories item
DSV 150V VTL 10/F	150	VTL 10/F	3 ~ 230/400-50Hz	DSO 300 97V	1600	G1"	152	FB 30 / FC 30
DSV 150V VTL 15/F	150	VTL 15/F	3 ~ 230/400-50Hz	DSO 300 97V	1600	G1"	164	FB 30 / FC 30
DSV 150V RVP 15	150	RVP 15	3 ~ 230/400-50Hz	DSO 300 97V	1600	G1"	174	FB 30 / FC 30
DSV 150V VTL 20/F	150	VTL 20/F	3 ~ 230/400-50Hz	DSO 300 97V	1600	G1"	167	FB 30 / FC 30
DSV 150V RVP 21	150	RVP 21	3 ~ 230/400-50Hz	DSO 300 97V	1600	G1"	160	FB 30 / FC 30
DSV 150V VTL 25/FG	150	VTL 25/FG	3 ~ 230/400-50Hz	DSO 300 97V	1600	G1"	168	FB 30 / FC 30
DSV 150V VTL 30/FG	150	VTL 30/FG	3 ~ 230/400-50Hz	DSO 300 97V	1600	G1"	172	FB 30 / FC 30
DSV 150V VTL 35/FG	150	VTL 35/FG	3 ~ 230/400-50Hz	DSO 300 97V	1600	G1"	174	FB 30 / FC 30

Note: All RVP pumps ... are equipped as standard with an FC filter ... suitable for the size of their suction connection.

VERTICAL SAFETY PUMP SETS DSV 300V ..

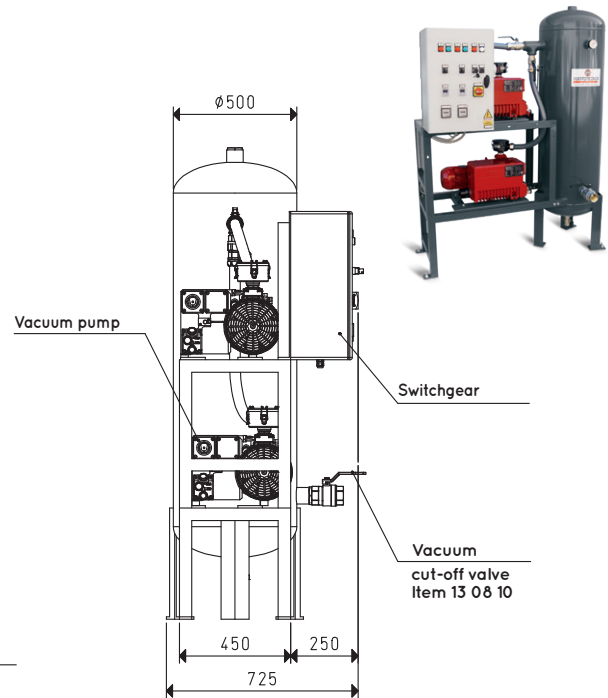
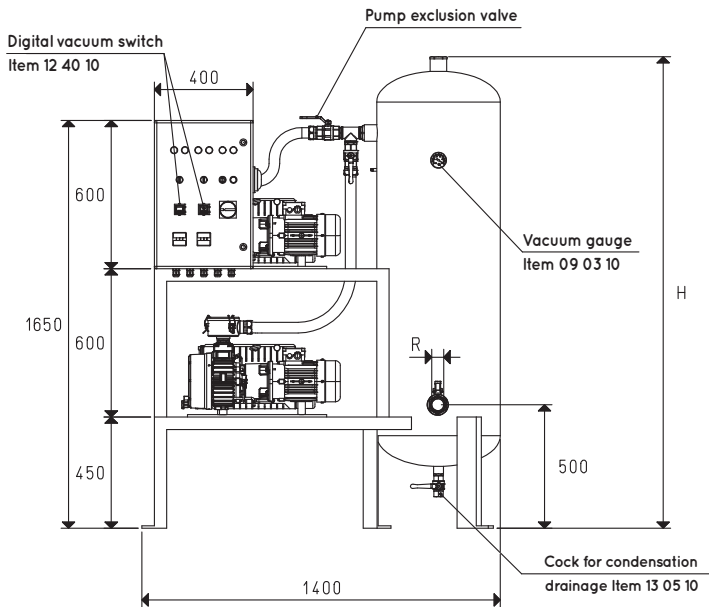

Item	Tank Litres	2 Pumps Mod.	Motor performance Volt	Switchgear item	H	R Ø	Weight Kg	Filter Accessories item
DSV 300V RVP 40	300	RVP 40	3 ~ 230/400-50Hz	DSO 300 97V	1890	G2"	223	FB 60 / FC 60
DSV 300V VTL 50/G1	300	VTL 50/G1	3 ~ 230/400-50Hz	DSO 300 97V	1890	G2"	226	FB 60 / FC 60
DSV 300V RVP 60	300	RVP 60	3 ~ 230/400-50Hz	DSO 300 97V	1890	G2"	237	FB 60 / FC 60
DSV 300V VTL 75/G1	300	VTL 75/G1	3 ~ 230/400-50Hz	DSO 300 97V	1890	G2"	249	FB 60 / FC 60
DSV 300V RVP 100	300	RVP 100	3 ~ 230/400-50Hz	DSO 300 97V	1890	G2"	246	FB 60 / FC 60
DSV 300V VTL 105/G1	300	VTL 105/G1	3 ~ 230/400-50Hz	DSO 300 97V	1890	G2"	270	FB 60 / FC 60

Note: All RVP pumps ... are equipped as standard with an FC filter ... suitable for the size of their suction connection.

Transformation ratio: N (newton) = Kg x 9.81 (force of gravity)

inch = $\frac{\text{mm}}{25.4}$; pounds = $\frac{\text{g}}{453.6} = \frac{\text{Kg}}{0.4536}$

Adapters for GAS - NPT threading available on page 1.130



VERTICAL SAFETY PUMP SETS DSV 500V ..

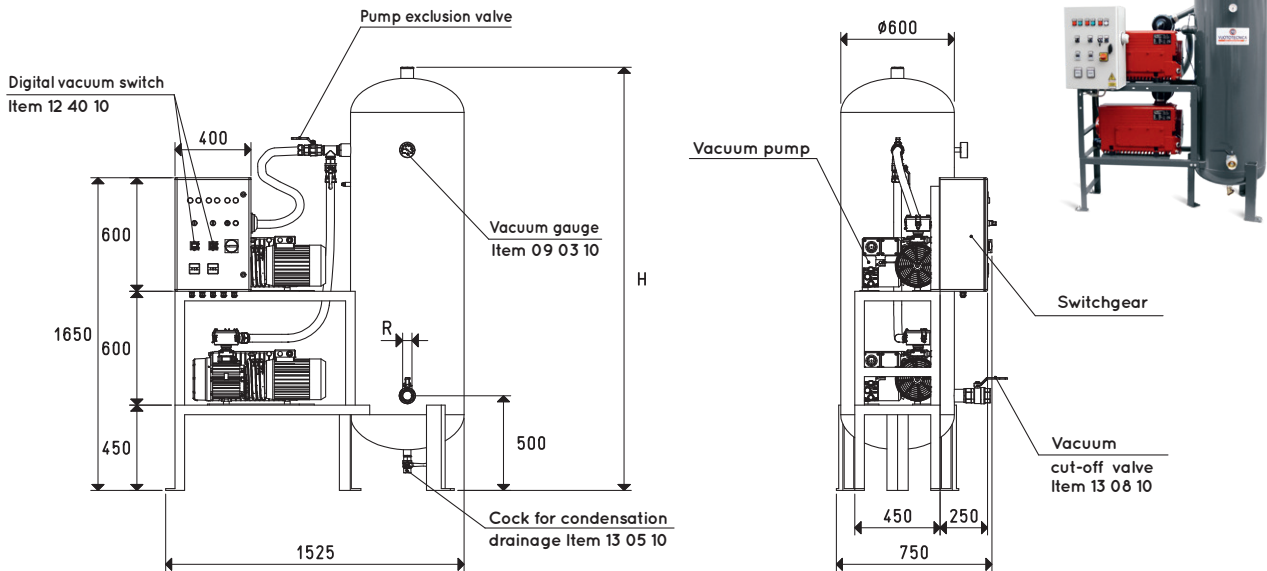

Item	Tank Litres	2 Pumps Mod.	Motor performance Volt	Switchgear item	H	R Ø	Weight Kg	Filter Accessories item
DSV 500V RVP 60	500	RVP 60	3 ~ 230/400-50Hz	DSO 300 97V	2220	G2"	320	FB 60 / FC 60
DSV 500V VTL 75/G1	500	VTL 75/G1	3 ~ 230/400-50Hz	DSO 300 97V	2220	G2"	355	FB 60 / FC 60
DSV 500V RVP 100	500	RVP 100	3 ~ 230/400-50Hz	DSO 300 97V	2220	G2"	359	FB 60 / FC 60
DSV 500V VTL 105/G1	500	VTL 105/G1	3 ~ 230/400-50Hz	DSO 300 97V	2220	G2"	396	FB 60 / FC 60
DSV 500V RVP 160	500	RVP 160	3 ~ 230/400-50Hz	DSO 300 97V	2220	G2"	491	FB 60 / FC 60
DSV 500V RVP 200	500	RVP 200	3 ~ 230/400-50Hz	DSO 300 97V	2220	G2"	497	FB 60 / FC 60

Note: All RVP pumps ... are equipped as standard with an FC filter ... suitable for the size of their suction connection.

VERTICAL SAFETY PUMP SETS DSV 1000V ..

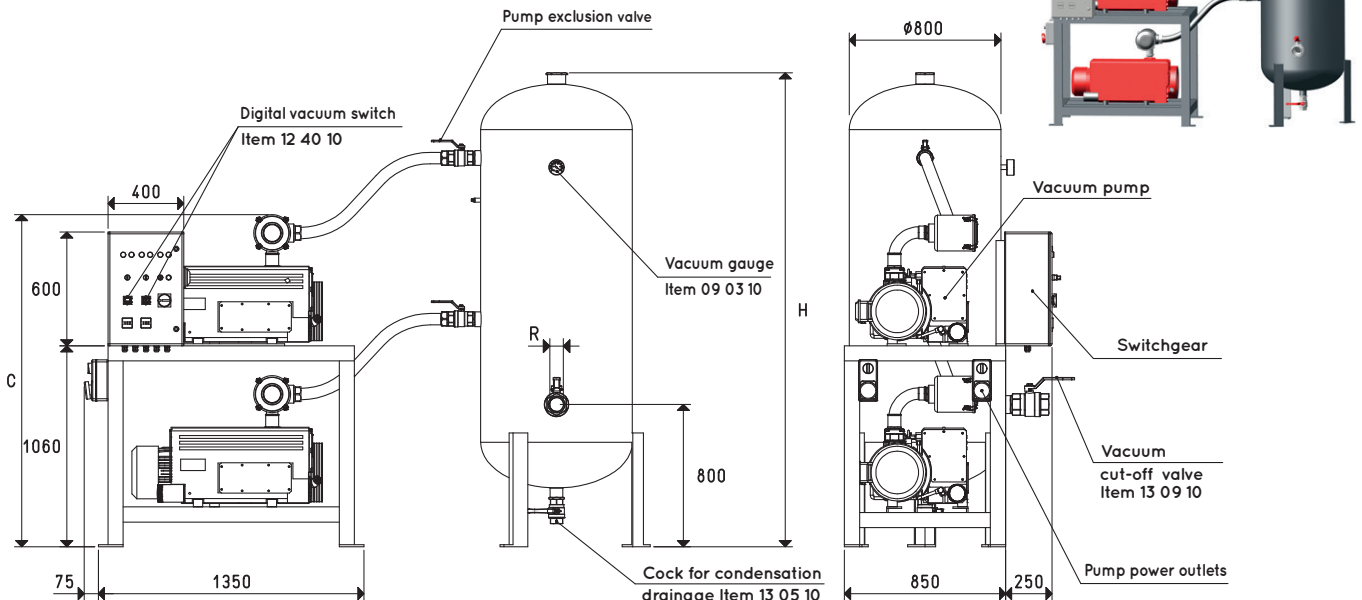

Item	Tank Litres	2 Pumps Mod.	Motor performance Volt	Switchgear item	C	H	R Ø	Weight Kg	Filter Accessories item
DSV 1000V RVP 160	1000	RVP 160	3 ~ 230/400-50Hz	DSO 300 97V	1751	2480	G3"	564	FC 80
DSV 1000V RVP 200	1000	RVP 200	3 ~ 230/400-50Hz	DSO 300 97V	1751	2480	G3"	570	FC 80
DSV 1000V RVP 250	1000	RVP 250	3 ~ 400/690-50Hz	DSO 300 97V	1751	2480	G3"	679	FC 80
DSV 1000V RVP 300	1000	RVP 300	3 ~ 400/690-50Hz	DSO 300 97V	1751	2480	G3"	707	FC 80

Note: All RVP pumps .. are equipped as standard with an FC filter .. suitable for the size of their suction connection.

Transformation ratio: N (newton) = Kg x 9.81 (force of gravity)

inch = $\frac{mm}{25.4}$; pounds = $\frac{g}{453.6} = \frac{Kg}{0.4536}$

Adapters for GAS - NPT threading available on page 1.130



VERTICAL SAFETY PUMP SETS DSV 2000V ..

3D drawings are available on vuototecnica.net

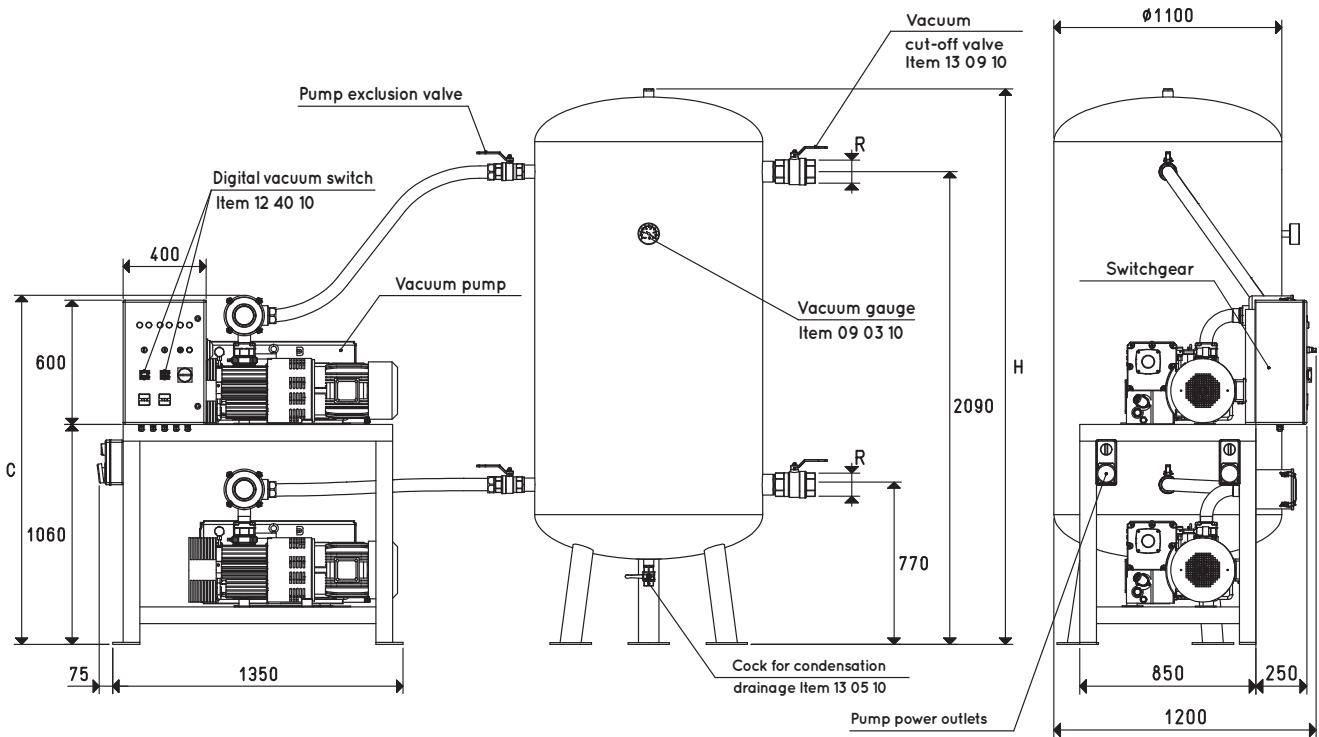
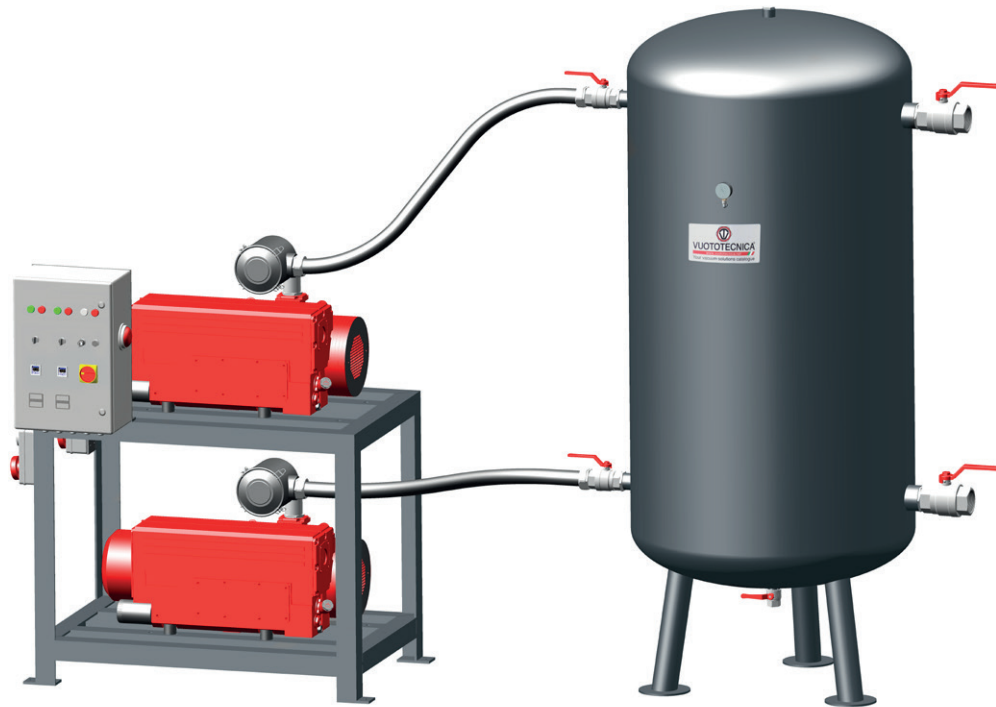

Item	Tank Litres	2 Pumps Mod.	Motor performance Volt	Switchgear item	C	H	R Ø	Weight Kg	Filter Accessories item
DSV 2000V RVP 200	2000	RVP 200	3 ~ 230/400-50Hz	DSO 300 97V	1751	2450	G3"	888	FC 80
DSV 2000V RVP 250	2000	RVP 250	3 ~ 400/690-50Hz	DSO 300 97V	1751	2450	G3"	996	FC 80
DSV 2000V RVP 300	2000	RVP 300	3 ~ 400/690-50Hz	DSO 300 97V	1751	2450	G3"	1040	FC 80

Note: All RVP pumps ... are equipped as standard with an FC filter ... suitable for the size of their suction connection.

Transformation ratio: N (newton) = Kg x 9.81 (force of gravity)

inch = $\frac{\text{mm}}{25.4}$; pounds = $\frac{\text{g}}{453.6} = \frac{\text{Kg}}{0.4536}$

Adapters for GAS - NPT threading available on page 1.130



DV300VRVP300FS50BP



DS3V500VRVP100