

Blechsauggreifer/Vacuum Suction Cups for Sheet "MaxiGrip"

Bevorzugter Einsatz: Automobil, Robotik, Glas, Marmor, Verpackungs- und Lebensmittelindustrie.

Die Standardmaterialien für Vakuumsauger sind NBR (+130° C), Naturgummi (+80° C), Silikon und FKM (+300° C). Wo Griffigkeit und hohe Ölbeständigkeit gefordert werden, schlagen wir unsere Blechsauggreifer **MaxiGrip** vor, die bis zu 170° C hitzebeständig sind.

Vorteile: Große Haltekraft und positionsstabil.

Alle Haltekraftangaben beziehen sich auf 75 % Vakuum und 3-fache Sicherheit, bezogen auf Meereshöhe.

Lagerhaltige Sauger aus FKM (Viton®) sind **rot** gekennzeichnet.

Preferred Use: Automobiles, robotics, glass, marble, packaging and food industries.

Standard materials for these suction cups are NBR (+130 °C), natural rubber (+80 °C), silicone and FKM (+300 °C). If superior grip and high resistance to oil are required, we recommend MaxiGrip sheet suction cups, which are resistant up to +170 °C.

Benefits: High holding force and positional stability.

All holding force data refer to 75% vacuum and triple safety margin, as referred to sea level.

Suction cups made of FKM (Viton®) are marked red.

Flachsauger Baureihe VRP Flat suction cups type VRP

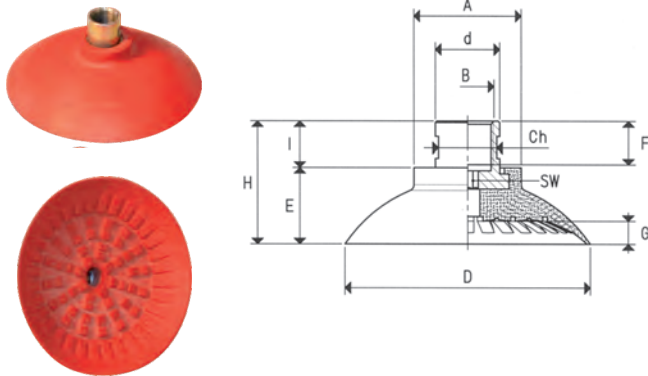

Art. Nr.	Haltekraft Holding force kg	A Ø	B	C	D Ø	d Ø	E	F	G	H	I	SW
VRP 40	3,14	26	G1/4"	15	40	17	16	14	4	31	15	6
VRP 50	4,90	30	G3/8"	19	50	21	18	14	5	33	15	6
VRP 60	7,06	30	G3/8"	19	60	21	21	14	6	36	15	6
VRP 80	12,56	35	G3/8"	19	80	21	25	14	7,5	40	15	6
VRP 100	19,62	35	G3/8"	19	100	21	25	14	9,5	40	15	6
VRP 125	30,66	35	G3/8"	19	125	21	33	14	12,5	48	15	6

Balgensauger Baureihe VRS Bellows suction cups type VRS

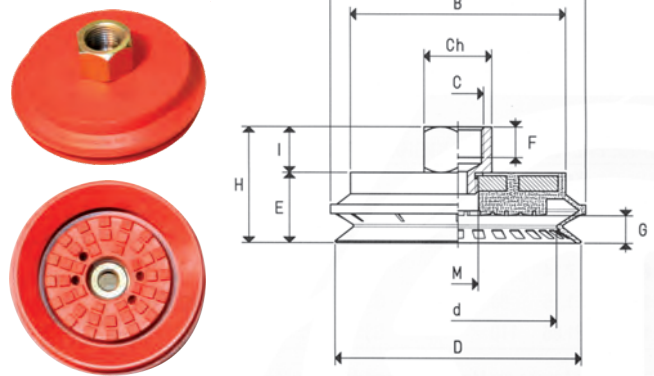

Art. Nr.	Haltekraft Holding force kg	A Ø	B Ø	C	D Ø	d Ø	E	F	G	H	I	M	SW
VRS 40	3,14	43	30	G1/4"	40	24	21	10	7	35	14	G1/8"	17
VRS 50	4,90	53	40	G3/8"	50	34	21	10	7	36	15	G1/4"	22
VRS 60	7,06	63	50	G3/8"	60	44	21	10	7	36	15	G1/4"	22
VRS 80	12,56	83	70	G3/8"	80	64	23	10	9	38	15	G1/4"	22
VRS 100	19,62	103	80	G3/8"	100	79	29	10	13	44	15	G1/4"	22
VRS 125	30,66	128	105	G3/8"	125	100	32,5	10	16,5	47,5	15	G1/4"	22

Ovalsauger Baureihe VEP Oval suction cups type VEP

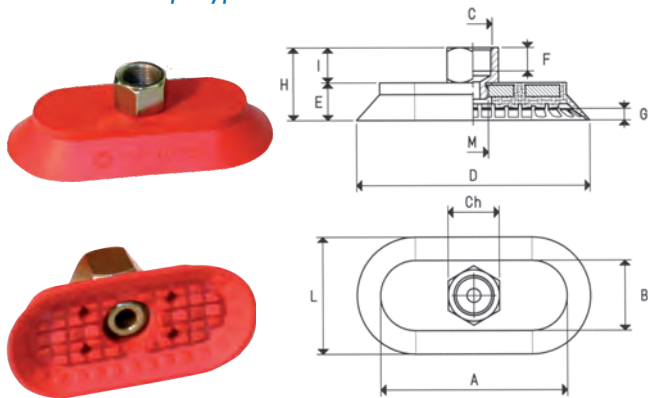

Art. Nr.	Haltekraft Holding force kg	A	B	C	D	E	F	G	H	I	L	M	SW
VEP 30 60	4,01	47	17	G1/4"	60	13	10	3	27	14	30	G1/8"	17
VEP 30 90	6,26	77	17	G1/4"	90	13	10	3	27	14	30	G1/8"	17
VEP 40 80	7,14	70	30	G1/4"	80	14	10	4	28	14	40	G1/8"	17
VEP 50 100	11,15	80	30	G3/8"	100	16	10	5	31	15	50	G1/4"	22
VEP 60 120	16,06	95	35	G3/8"	120	18	10	6	33	15	60	G1/4"	22
VEP 70 140	21,86	110	40	G3/8"	140	19	10	7	34	15	70	G1/4"	22

Oval-Balgensauger Baureihe VES Oval suction cups type VES

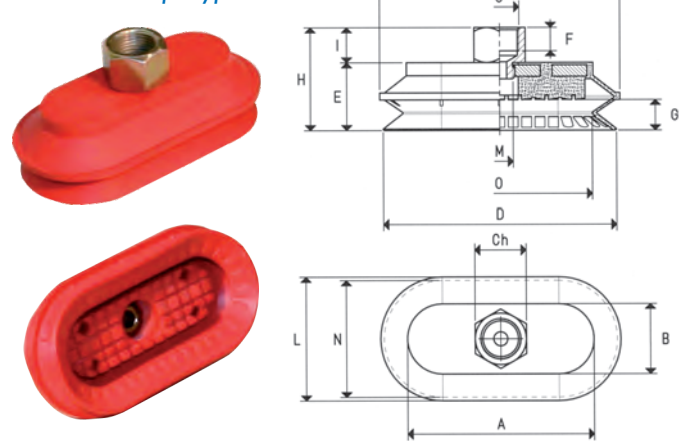

Art. Nr.	Haltekraft Holding force kg	A	B	C	D	E	F	G	H	K	I	L	M	N	O	SW
VES 30 60	4,01	50	20	G1/4"	60	21	10	7	35	63	14	33	G1/8"	30	44,5	17
VES 40 80	7,14	70	30	G1/4"	80	23	10	9	37	83	14	43	G1/8"	40	64	17
VES 50 100	11,15	80	30	G3/8"	100	29	10	13	44	103	15	53	G1/4"	50	79	22
VES 70 140	21,86	110	40	G3/8"	140	33	10	16,5	48	143	15	73	G1/4"	70	109	22

Änderungen im Sinne des technischen Fortschrittes vorbehalten. Copyright by MF Automation. Jede Nachahmung kann gerichtlich verfolgt werden.

Specifications and design subject to change without notice. Infringements will be prosecuted

Blechsauggreifer/Vacuum Suction Cups for Sheet "MaxiGrip"

- Vorteile: unzählige Anschlussvarianten, adaptier- und austauschbar auch zu bestehenden Systemen.

- Benefits: Countless fitting options, adaptable and interchangeable with existing systems.

MF-Reduzierung für Sauger VRP MF Reducer for VRP suction cups

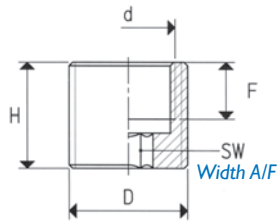

Art. Nr.	D	d	F	H	SW
00 08 215	G3/8"	G 1/4"	8	14	6

MF-Reduzierung für Sauger VRS-VEP-VES MF Reducer for VRS-VEP-VES suction cups

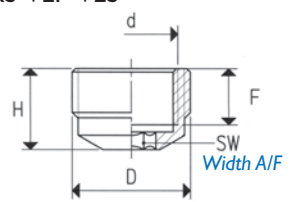

Art. Nr.	D	d	F	H	SW
00 08 216	G3/8"	G 1/4"	8	11,5	6
00 08 216.14	G 1/4"	G 1/8"	-	8	-

MF-Reduzierung für Sauger VRP MF Reducer for VRP suction cups

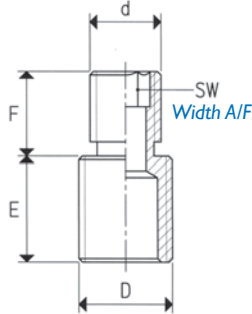

Art. Nr.	E	F	D	d	SW
00 08 217	15	10	G1/4"	G1/4"	6
00 08 218	15	12	G1/4"	M10x1,5	6
00 08 219	15	12	G1/4"	M14x1,5	6
00 08 220	14	10	G3/8"	G1/4"	6
00 08 221	14	12	G3/8"	M10x1,5	6
00 08 222	14	12	G3/8"	M14x1,5	6

MF-Reduzierung für Sauger VRS-VEP-VES MF Reducer for VRS-VEP-VES suction cups

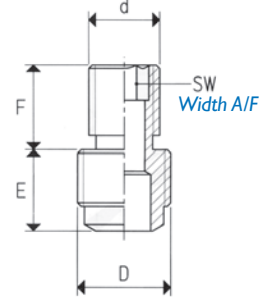

Art. Nr.	E	F	D	d	SW
00 08 223	11,5	10	G1/4"	G1/4"	6
00 08 224	13	12	G1/4"	M10x1,5	6
00 08 225	13	12	G1/4"	M14x1,5	6
00 08 226	10,5	11	G3/8"	G1/4"	6
00 08 227	10,5	13	G3/8"	M10x1,5	6
00 08 228	10,5	13	G3/8"	M14x1,5	6

MF-Reduzierung für Sauger VRP-VRS-VEP-VES MF Reducer for suction cups VRP-VRS-VEP-VES

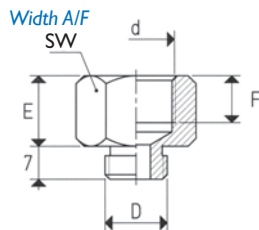

Art. Nr.	E	F	D	d	SW
00 08 208	15	9	G1/4"	G3/8"	22

Schnellwechseladapter für Sauger VRP-VRS-VEP-VES Quick-change adapters for VRP-VRS-VEP-VES suction cups

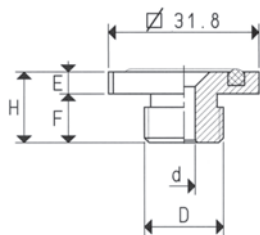
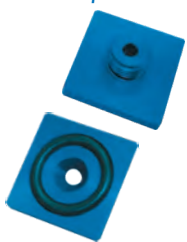

Art. Nr.	H	E	F	D	d
AQ 32 1/4"	13	5	8	G1/4"	5
AQ 32 3/8"	13	5	8	G3/8"	5

Kugelgelenke, einstellbar Ball Joints, adjustable

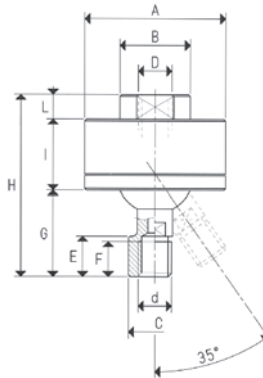

Kugelgelenke in verschiedenen Anschlussvarianten bis 35° fix einstellbar

Ball Joints with various fitting options, adjustable to 35°



Art. Nr.	A Ø	B Ø	C Ø	D	d	E	F	G	H	I	L	max. zugl. Gewicht max. adm. weight kg
GSV 1/8"	40	20	--	G1/8"	G1/8"	11,5	10	24,5	51,5	20	7	18,24
GSV 1/4"	45	25	--	G1/4"	G1/4"	14,5	12	28,5	60,5	25	7	23,54
GSV 3/8"	50	30	--	G3/8"	G3/8"	14	12	34,5	69,5	25	10	33,91
GSVF 1/8"	40	20	15	G1/8"	G1/8"	11,5	10	24,5	51,5	20	7	18,24
GSVF 1/4"	45	25	20	G1/4"	G1/4"	14,5	12	28,5	60,5	25	7	23,54
GSVF 3/8"	50	30	21	G3/8"	G3/8"	17	12	34,5	69,5	25	10	33,91

Änderungen im Sinne des technischen Fortschrittes vorbehalten. Copyright by MF Automation. Jede Nachahmung kann gerichtlich verfolgt werden.

Specifications and design subject to change without notice. Infringements will be prosecuted

Blechsauger MaxiGrip

Anschlussadapter für „MaxiGrip“-Adapter, Serie AQ und AQS Connection Adapters for „MaxiGrip“-Adapters, Series AQ and AQS

Zum schnellen Wechseln von Vakuumsaugern der Baureihe „MaxiGrip“.

For fast changing of vacuum suction cups of the series „MaxiGrip“.

Einsatz:

- in Greifsystemen zum Blechhandling
- und in der Automobil-Industrie usw.

Use:

- in gripper systems for sheet handling
- and in the automotive industrie etc.

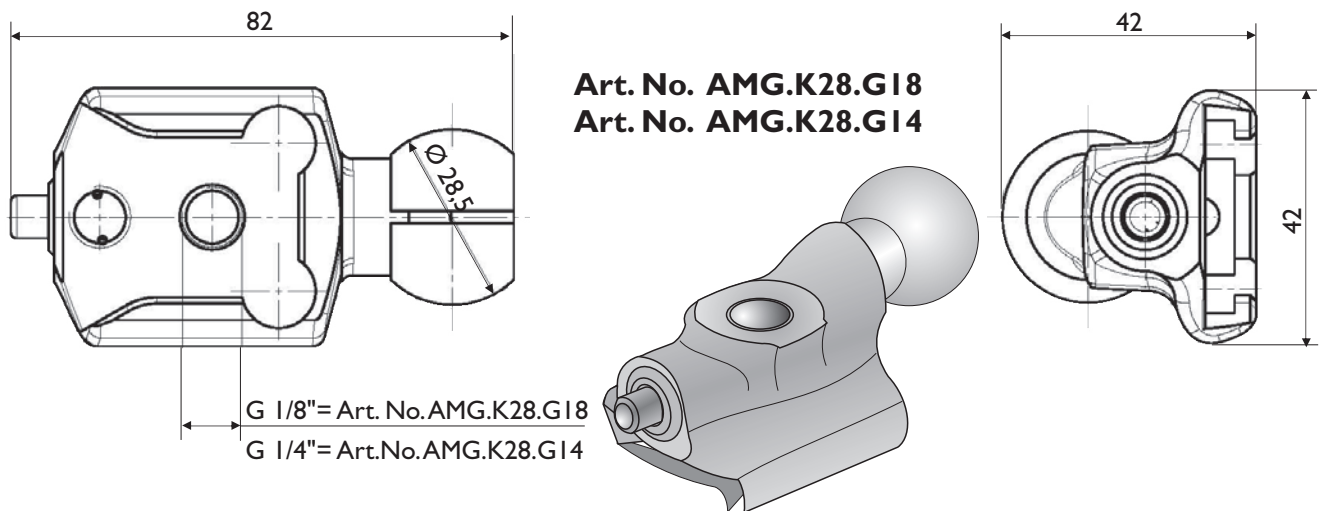
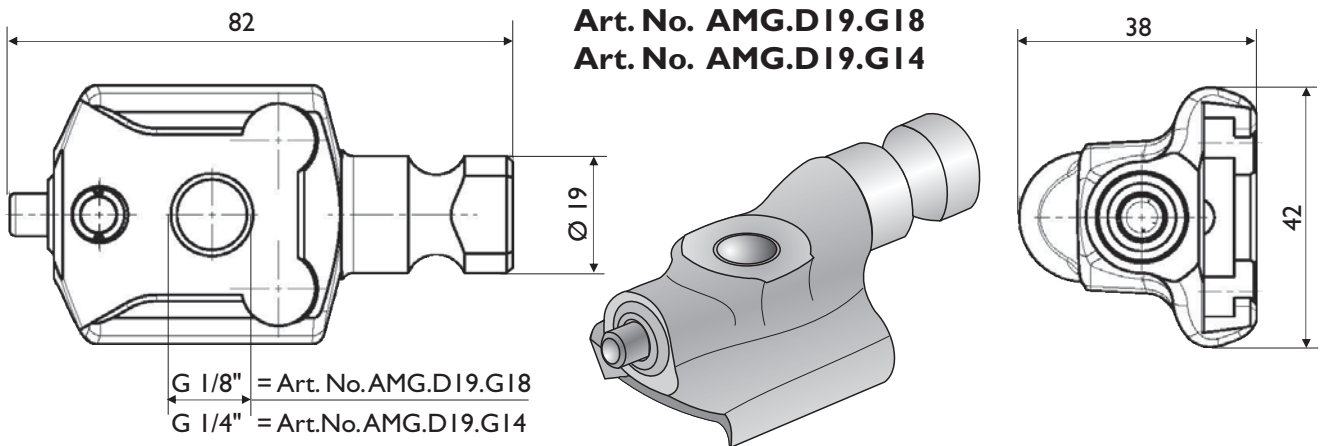

MaxiGrip mit Adapter AQ + AQS
MaxiGrip with adapter AQ + AQS

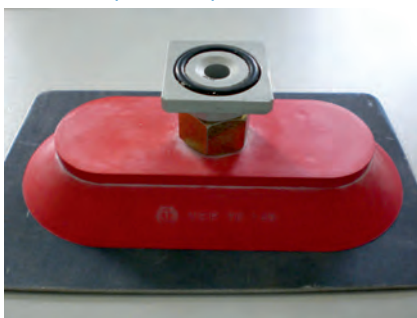

MaxiGrip mit/with AMG.DI9



MaxiGrip mit/with AMG.K28



Änderungen im Sinne des technischen Fortschrittes vorbehalten. Copyright by MF Automation. Jede Nachahmung kann gerichtlich verfolgt werden.

Specifications and design subject to change without notice. Infringements will be prosecuted

Blechsauger MaxiGrip